

Visit www.carrier.com

Installation and Start-Up Instructions

NOTE: Read the entire instruction manual before starting the installation.

This symbol → indicates a change since the last issue.

SAFETY CONSIDERATIONS

Improper installation, adjustment, alteration, service, maintenance, or use can cause explosion, fire, electrical shock, or other conditions which may cause death, personal injury, or property damage. Consult a qualified installer, service agency, or your distributor or branch for information or assistance. The qualified installer or agency must use factory-authorized kits or accessories when modifying this product. Refer to the individual instructions packaged with the kits or accessories when installing.

Follow all safety codes. Wear safety glasses, protective clothing, and work gloves. Use quenching cloth for brazing operations. Have fire extinguisher available. Read these instructions thoroughly and follow all warnings or cautions included in literature and attached to the unit. Consult local building codes and National Electrical Code (NEC) for special requirements.

Recognize safety information. This is the safety-alert symbol . When you see this symbol on the unit and in instructions or manuals, be alert to the potential for personal injury.

Understand the signal words DANGER, WARNING, and CAUTION. These words are used with the safety-alert symbol. DANGER identifies the most serious hazards which **will** result in severe personal injury or death. WARNING signifies hazards which **could** result in personal injury or death. CAUTION is used to identify unsafe practices which **would** result in minor personal injury or product and property damage. NOTE is used to highlight suggestions which **will** result in enhanced installation, reliability, or operation.

WARNING

Before installing, modifying, or servicing system, main electrical disconnect switch must be in the OFF position. There may be more than 1 disconnect switch. Lock out and tag switch(es) with a suitable warning label. Electrical shock can cause personal injury or death.

INTRODUCTION AND RECOMMENDATIONS

NOTE: In some cases noise has been traced to improper installation of equipment.

1. Locate unit away from windows, patios, decks, and so forth where unit operation sounds may disturb customer.
2. Ensure that vapor- and liquid-tube diameters are appropriate to capacity of unit.
3. Run refrigerant tubes as directly as possible by avoiding unnecessary turns and bends.

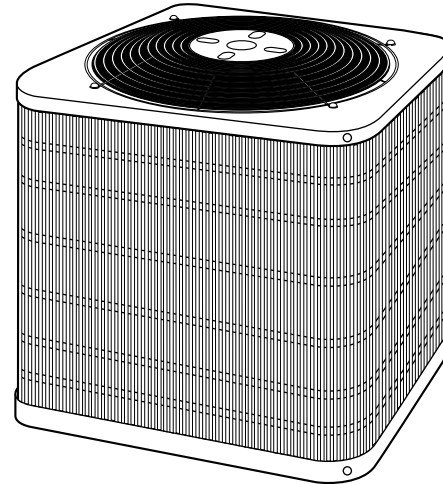

A98525

Fig. 1—Model 38YCW

4. Leave some slack between structure and unit to absorb vibration.
5. When passing refrigerant tubes through the wall, seal opening with RTV or other pliable silicon-based caulk. (See Fig. 2.)
6. Avoid direct refrigerant tubing contact with water pipes, duct work, floor joists, wall studs, floors, and walls.
7. Do not suspend refrigerant tubing from joists and studs with a rigid wire or strap that comes in direct contact with tubing. (See Fig. 2.)
8. Ensure that refrigerant tubing insulation is pliable and completely surrounds vapor tube.
9. When necessary, use hanger straps which are 1 in. wide and conform to shape of tubing insulation. (See Fig. 2.)
10. Isolate hanger straps from insulation by using metal sleeves bent to conform to shape of insulation.

When outdoor unit is connected to factory-approved indoor unit, outdoor unit contains system-refrigerant charge for operation with indoor unit of the same size when connected by 15 ft of field-supplied or factory-accessory tubing. For proper unit operation, check refrigerant charge using charging information located on control-box cover and/or in the Check Charge section of this Instruction.

IMPORTANT: Maximum liquid-line size is 5/8-in. O.D. for all residential applications including long line applications.

IMPORTANT: Always install a liquid-line filter drier. Refer to Product Data Digest for appropriate part number. Obtain filter drier from your distributor or branch.

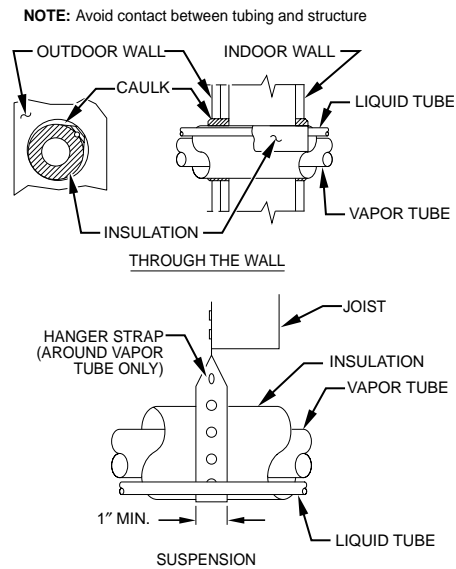

A94028

Fig. 2—Connecting Tubing Installation

INSTALLATION

Step 1—Check Equipment and Job Site

UNPACK UNIT

Move to final location. Remove carton, taking care not to damage unit.

INSPECT EQUIPMENT

File claim with shipping company prior to installation if shipment is damaged or incomplete. Locate unit-rating plate on unit-service panel. It contains information needed to properly install unit. Check rating plate to be sure unit matches job specifications.

Step 2—Install on a Solid, Level Mounting Pad

If conditions or local codes require the unit be attached to pad, tie-down bolts should be used and fastened through knockouts provided in unit base pan. Refer to unit-mounting pattern in Fig. 3 to determine base-pan size and knockout-hole location.

On rooftop applications, mount on level platform or frame 6 in. above roof surface. Place unit above a load-bearing wall and isolate unit and tubing set from structure. Arrange supporting members to adequately support unit and minimize transmission of vibration to building. Consult local codes governing rooftop applications.

Roof-mounted units exposed to winds above 5 mph may require wind baffles to achieve adequate defrost. Consult Low-Ambient Guideline for wind-baffle construction.

NOTE: Unit must be level to within $\pm 2^\circ$ ($\pm 3/8$ in./ft) per compressor manufacturer specifications.

Step 3—Clearance Requirements

When installing, allow sufficient space for airflow clearance, wiring, refrigerant piping, and service. Allow 30-in. clearance to service end of unit and 48 in. above unit. For proper airflow, a 6-in. clearance on 1 side of unit and 12 in. on all remaining sides must be maintained. Maintain a distance of 24 in. between units. Position so water, snow, or ice from roof or eaves cannot fall directly on unit.

On rooftop applications, locate unit at least 6 in. above roof surface.

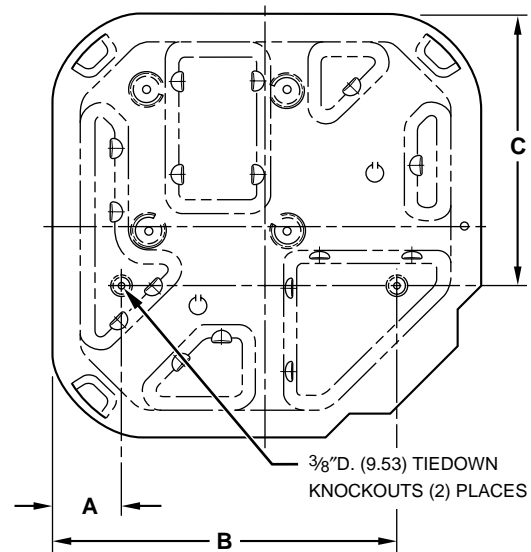

A94199

Dimensions (In.)

UNIT SIZE	MINIMUM MOUNTING-PAD DIMENSIONS	TIEDOWN KNOCKOUT LOCATIONS		
		A	B	C
018–030	22-1/2 x 22-1/2	3-11/16	18-1/8	14-3/8
036–060	30 x 30	6-1/2	23-1/2	20

Fig. 3—Mounting Unit to Pad

Step 4—Operating Ambients

The minimum outdoor-operating ambient in cooling mode is 55°F, and the maximum outdoor-operating ambient in cooling mode is 125°F. The maximum outdoor-operating ambient in heating mode is 66°F.

Step 5—Elevate Unit

⚠ CAUTION

Accumulation of water and ice in base pan may cause equipment damage.

In areas where prolonged freezing temperatures are encountered, elevate unit per local climate and code requirements to provide clearance above estimated snowfall level and ensure adequate drainage of unit.

Step 6—Check Indoor And Outdoor AccuRater® Piston

Check indoor-coil piston to see if it matches the required piston shown on outdoor unit-rating plate. If it does not match, replace indoor-coil piston with piston shipped with outdoor unit. The piston shipped with outdoor unit is correct for any approved indoor-coil combination.

⚠ CAUTION

Remove indoor-coil piston if unit is to be installed on system with a TXV-metering device.

Step 7—Check Defrost Thermostat

Check defrost thermostat to ensure it is properly located and securely attached. There is a liquid header with a brass distributor and feeder tube going into outdoor coil. At the end of 1 of the feeder tubes, there is a 3/8-in. O.D. stub tube approximately 3 in. long. The defrost thermostat should be located on stub tube. Note that there is only 1 stub tube used with liquid header, and on most units it is the bottom circuit.

Table 1—Refrigerant Connections and Recommended Liquid- and Vapor-Tube Diameters (In.)

UNIT SIZE	LIQUID		VAPOR		VAPOR (LONG LINE)	
	Connection Diameter	Tube Diameter	Connection Diameter	Tube Diameter	Connection Diameter	Tube Diameter
018, 024	3/8	3/8	3/4	3/4	3/4	3/4
030, 036	3/8	3/8	3/4	3/4	3/4	7/8
042, 048	3/8	3/8	7/8	7/8	7/8	1-1/8
060	3/8	3/8	7/8	1-1/8	7/8	1-1/8

NOTES:

1. Tube diameters are for lengths up to 50 ft. For tubing lengths greater than 50 ft, consult Long Line section of the Application Guideline.
2. Do not apply capillary-tube indoor coils to these units.

Step 8—Make Piping Connections

⚠ WARNING

Relieve pressure and recover all refrigerant before system repair or final unit disposal to avoid personal injury or death. Use all service ports and open all flow-control devices, including solenoid valves.

⚠ CAUTION

If ANY refrigerant tubing is buried, provide a 6 in. vertical rise at service valve. Refrigerant tubing lengths up to 36 in. may be buried without further special consideration. For lengths above 36 in., consult your local distributor.

⚠ CAUTION

To prevent damage to unit or service valves observe the following:

- Use a brazing shield.
- Wrap service valves with wet cloth or use a heat-sink material.

Outdoor units may be connected to indoor section using accessory-tubing package or field-supplied refrigerant-grade tubing of correct size and condition. For tubing requirements beyond 50 ft length or 20 ft vertical differential, substantial capacity and performance losses can occur. Following the recommendations in the Residential Split-System Long-Line Application Guideline will reduce these losses. Refer to Table 1 for field-tubing diameters.

REFRIGERANT TUBING

Connect tubing to fittings on outdoor unit vapor- and liquid-service valves. (See Table 1.) Use refrigerant-grade tubing. Refer to appropriate section below for type of service valves installed on unit.

SWEAT CONNECTION

⚠ CAUTION

To avoid valve damage while brazing, service valves must be wrapped in a heat-sinking material such as a wet cloth.

1. Remove plastic retainer holding outdoor piston in liquid-service valve.
2. Locate adapter tube shipped with unit.
3. Install strainer in adapter tube and connect tube to service valve. (See Fig. 4.)
4. Connect refrigerant tubing to fittings on outdoor-unit vapor- and liquid-service valves.
5. Service valves are closed from factory and ready for brazing. After wrapping service valve with a wet cloth, tubing set can be brazed to service valve using either silver-bearing or

non-silver-bearing brazing material. Consult local code requirements.

Refrigerant tubing and indoor coil are now ready for leak testing. This check should include all field and factory joints.

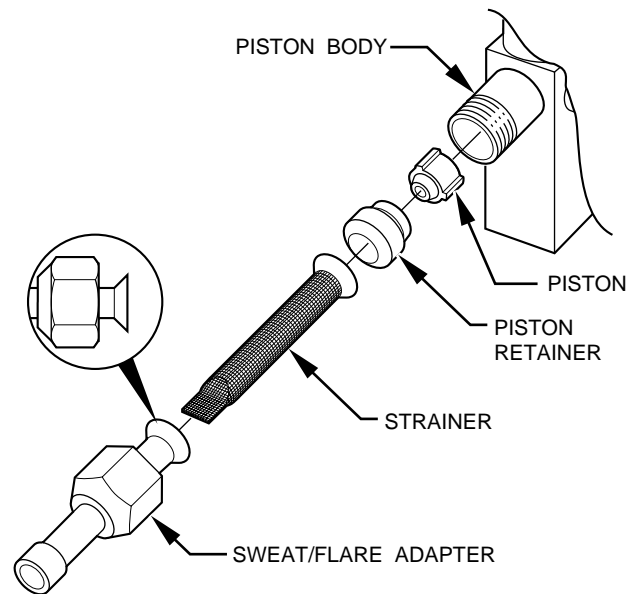

A97512

Fig. 4—Liquid-Service Valve with Sweat-Adapter Tube

FINAL TUBING CHECK

IMPORTANT: Check to be certain factory tubing on both indoor and outdoor unit has not shifted during shipment. Ensure tubes are not rubbing against each other or any sheet metal. Pay close attention to feeder tubes, making sure wire ties on feeder tubes are secure and tight.

Step 9—Make Electrical Connections

⚠ WARNING

To avoid personal injury or death, do not supply power to unit with compressor terminal-box cover removed.

Be sure field wiring complies with local and national fire, safety, and electrical codes, and voltage to system is within limits shown on unit-rating plate. Contact local power company for correction of improper voltage. See unit-rating plate for recommended circuit-protection device.

NOTE: Operation of unit on improper line voltage constitutes abuse and could affect unit reliability. See unit-rating plate. Do not install unit in system where voltage or phase imbalance (3 phase) may fluctuate above or below permissible limits.

NOTE: Use copper wire only between disconnect switch and unit.

NOTE: Install branch-circuit disconnect of adequate size per NEC to handle unit-starting current. Locate disconnect within sight from and readily accessible from unit, per Section 440-14 of NEC.

ROUTE GROUND AND POWER WIRES

Remove access panel and control box to gain access to unit wiring. Extend wires from disconnect through power-wiring hole provided and into unit-control box.

⚠ WARNING

The unit cabinet must have an uninterrupted or unbroken ground to minimize personal injury if an electrical fault should occur. The ground may consist of electrical wire or metal conduit when installed in accordance with existing electrical codes. Failure to follow this warning can result in an electric shock, fire, or death.

CONNECT GROUND AND POWER WIRES

Connect ground wire to ground connection in control box for safety. Connect power wiring to contactor as shown in Fig. 5.

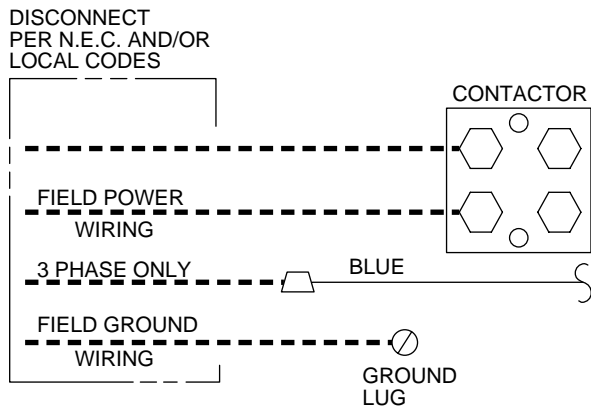

A94025

Fig. 5—Line Power Connections

CONNECT CONTROL WIRING

Route 24v control wires through control-wiring grommet and connect leads to control wiring. Refer also to Installation Instructions packaged with thermostat.

Use No. 18 AWG color-coded, insulated (35°C minimum) wire. If thermostat is located more than 100 ft from unit, as measured along the control-voltage wires, use No. 16 AWG color-coded wire to avoid excessive voltage drop.

All wiring must be NEC Class 1 and must be separated from incoming power leads.

Use furnace transformer, fan-coil transformer, or accessory transformer for control power, 24v/40va minimum.

NOTE: Use of available 24v accessories may exceed the minimum 40va power requirement. Determine total transformer loading and increase the transformer capacity or split the load with an accessory transformer as required.

FINAL WIRING CHECK

IMPORTANT: Check factory wiring and field-wire connections to ensure terminations are secured properly. Check wire routing to ensure wires are not in contact with tubing, sheet metal, and so forth.

Step 10—Compressor Crankcase Heater

When equipped with a crankcase heater, furnish power to heater a minimum of 24 hr before starting unit. To furnish power to heater

only, set thermostat to OFF and close electrical disconnect to outdoor unit. A crankcase heater is required if refrigerant tubing is longer than 50 ft.

Step 11—Install Electrical Accessories

Refer to the individual instructions packaged with kits or accessories when installing.

Step 12—Start-Up

⚠ CAUTION

To prevent compressor damage or personal injury, observe the following:

- Do not overcharge system with refrigerant.
 - Do not operate unit in a vacuum or at negative pressure.
 - Do not disable low-pressure switch.
- In scroll compressor applications:
- Dome temperatures may be hot.

⚠ CAUTION

To prevent personal injury wear safety glasses, protective clothing, and gloves when handling refrigerant and observe the following:

- Back-seating service valves are not equipped with Schrader valves. Fully back seat (counterclockwise) valve stem before removing gage-port cap.
- Front-seating service valves are equipped with Schrader valves.

⚠ CAUTION

Do not vent refrigerant to atmosphere. Recover during system repair or final unit disposal.

If refrigerant tubes or indoor coil are exposed to atmosphere, they must be evacuated to 500 microns to eliminate contamination and moisture in the system.

Follow these steps to properly start up the system:

1. Fully back seat (open) liquid- and vapor-tube service valves.
2. Unit is shipped with valve stem(s) front seated (closed) and caps installed. Replace stem caps after system is opened to refrigerant flow. Replace caps finger-tight and tighten with wrench an additional 1/12 turn.
3. Close electrical disconnects to energize system.
4. Set room thermostat to desired temperature. Be sure set point is below indoor ambient temperature.
5. Set room thermostat to HEAT or COOL and fan control to ON or AUTO, as desired. Operate unit for a minimum of 15 minutes. Check system refrigerant charge.

⚠ CAUTION

- 3-phase scroll compressors are rotation sensitive.
- A flashing LED on phase monitor indicates reverse rotation. (See Fig. 7 and Table 2.) This will not allow contactor to be energized.
- Disconnect power to unit and interchange 2 field-wiring leads on unit contactor.

Step 13—Check Charge

Factory charge is shown on unit-rating plate. To check charge in cooling mode, refer to Cooling-Only Procedure on unit wiring and charging label.

COOLING-ONLY PROCEDURE

NOTE: If superheat- or subcooling-charging conditions are not favorable, charge must be weighed in accordance with unit-rating plate ± 0.6 oz/ft of 3/8-in. liquid line above or below 15 ft respectively.

EXAMPLE:

To calculate additional charge required for a 25-ft line set:

$$25 \text{ ft} - 15 \text{ ft} = 10 \text{ ft} \times 0.6 \text{ oz/ft} = 6 \text{ oz of additional charge}$$

HEATING CHECK-CHART PROCEDURE

To check system operation during heating cycle, refer to the Heating Check Chart on outdoor unit. This chart indicates whether a correct relationship exists between system operating pressure and air temperature entering indoor and outdoor units. If pressure and temperature do not match on chart, system-refrigerant charge may not be correct. Do not use chart to adjust refrigerant charge.

NOTE: When charging is necessary during heating season, charge must be weighed in accordance with unit rating plate ± 0.6 oz/ft of 3/8-in. liquid line above or below 15 ft respectively.

Step 14—Final Checks

IMPORTANT: Before leaving job, be sure to do the following:

1. Securely fasten all panels and covers.
2. Tighten service valve-stem caps to 1/12-turn past finger-tight.
3. Leave User’s Manual with owner. Explain system operation and periodic maintenance requirements outlined in manual.
4. Fill out Dealer Installation Checklist and place in customer file.

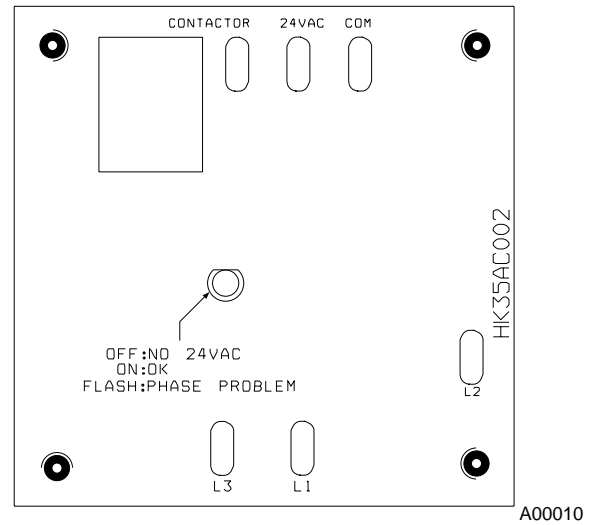
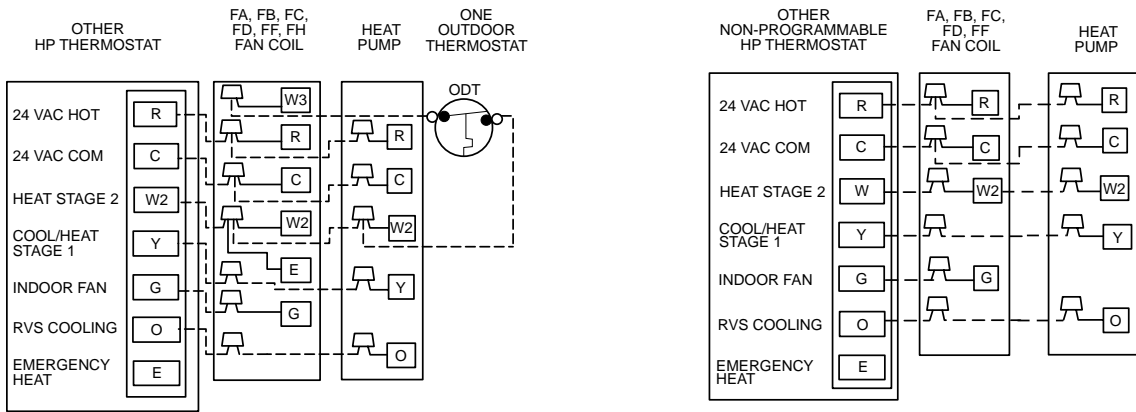

Table 2—Phase-Monitor LED Indicators

LED	STATUS
OFF	No call for compressor operation
FLASHING	Reversed phase
ON	Normal

Fig. 7—Phase-Monitor Control



NOTE: Remove wires from crimp nut in indoor fan coil when installing outdoor thermostat.

IMPORTANT: When using outdoor thermostat, W₂ must be energized when requesting supplemental heat.

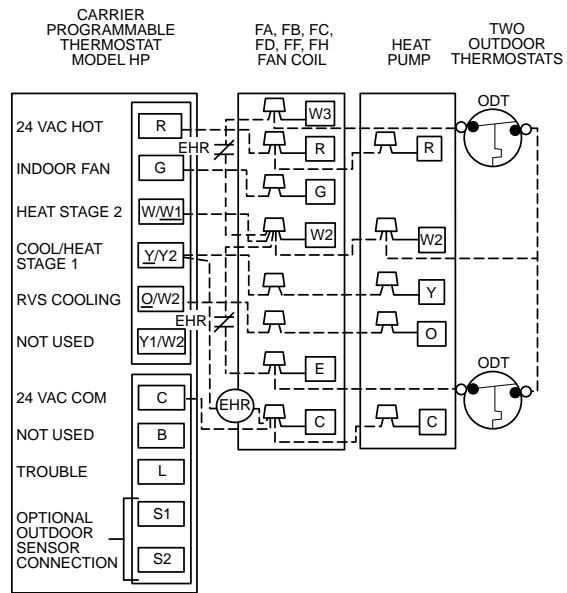
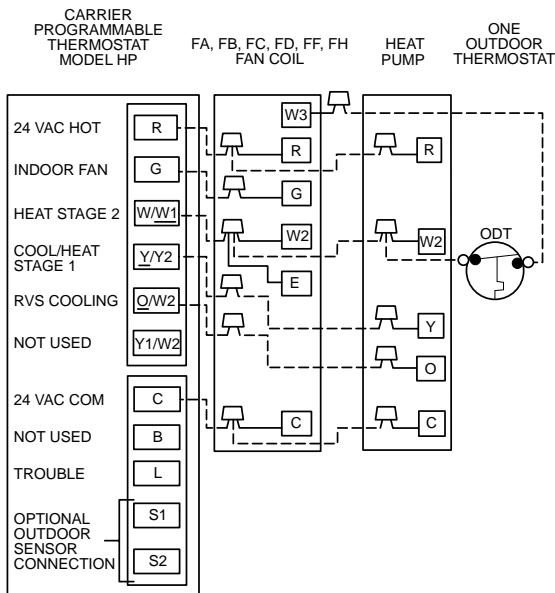
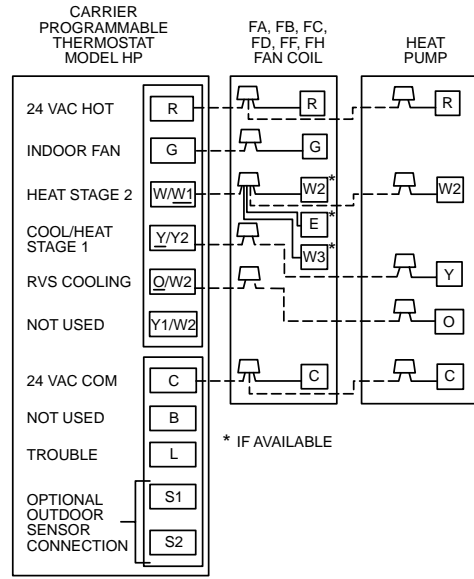
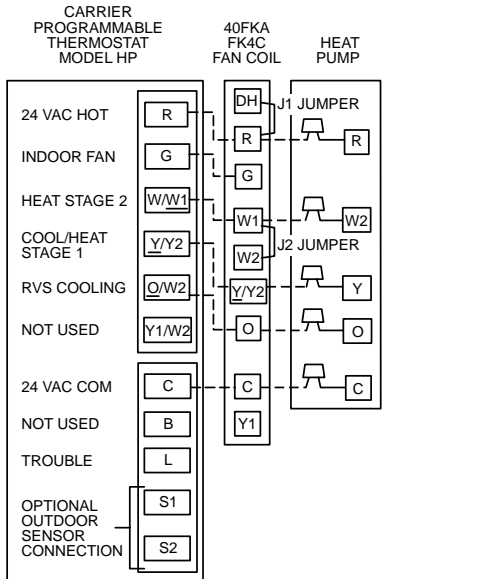

NOTE: Remove wires from crimp nut in indoor fan coil when installing outdoor thermostat.

IMPORTANT: When using outdoor thermostat, W₂ must be energized when requesting supplemental heat.

NOTE: Remove wires from crimp nut in indoor fan coil when installing outdoor thermostats.

IMPORTANT: When using outdoor thermostats, W₂ must be energized when requesting supplemental heat.

Fig. 6—Typical 24v Circuit Connections

WIRING DIAGRAM NOTES:

1. CARRIER THERMOSTAT-WIRING DIAGRAMS ARE ONLY ACCURATE FOR MODEL NUMBERS BEGINNING WITH TSTAT_-----.
2. WIRING MUST CONFORM TO NEC OR LOCAL CODES.
3. SOME UNITS ARE EQUIPPED WITH PRESSURE SWITCH(ES), TEMPERATURE SWITCH, OR 5-MINUTE COMPRESSOR-CYCLE PROTECTION. CONNECT 24V FIELD WIRING TO FACTORY-PROVIDED STRIPPED LEADS.
4. THERMOSTATS ARE FACTORY CONFIGURED WITH 5-MINUTE COMPRESSOR-CYCLE PROTECTION AND 4-CYCLES-PER-HR LIMIT. SEE THERMOSTAT-INSTALLATION INSTRUCTIONS FOR DETAILS.
5. TO STAGE ELECTRIC-RESISTANCE HEAT, CONSULT OUTDOOR THERMOSTAT-INSTALLATION INSTRUCTIONS.
6. UNDERLINED LETTER ON DUAL TERMINAL INDICATES ITS USAGE.
FOR EXAMPLE: O/W2 MEANS O; O/W2MEANS W2
7. OUTDOOR-TEMPERATURE SENSOR MUST BE ATTACHED IN ALL DUAL-FUEL INSTALLATIONS. JUMPER WIRE BETWEEN O/W2 AND L THERMOSTAT TERMINALS MUST BE PRESENT.
8. Y1 AND O CONNECTIONS TO 2-STAGE FURNACES **MAY NOT EXIST** OR MAY ONLY BE A WIRE RATHER THAN A SCREW TERMINAL.

SEQUENCE OF OPERATION

NOTE: Defrost-control board is equipped with 5-minute lockout timer that may be initiated upon any interruption of power.

With power supplied to indoor and outdoor units, transformer is energized.

Cooling

On a call for cooling, thermostat makes circuits R-O, R-Y, and R-G. Circuit R-O energizes reversing valve, switching it to cooling position. On 3-phase models with scroll compressors, the units are equipped with a phase monitor to detect if the incoming power is correctly phased for compressor operation. If phasing is correct, circuit R-Y energizes contactor, starting outdoor-fan motor and compressor circuit. R-G energizes indoor unit-blower relay, starting indoor-blower motor on high speed.

NOTE: If the phasing is incorrect, the contactor will not be energized. To correct the phasing, interchange any 2 of the 3 power connections on the field side.

When thermostat is satisfied, its contacts open, de-energizing the contactor and blower relay. Compressor and motors should stop.

NOTE: If indoor unit is equipped with a time-delay relay circuit, the blower runs an additional 90 sec to increase system efficiency.

Heating

On a call for heating, thermostat makes circuits R-Y and R-G. If phasing is correct, circuit R-Y energizes contactor, starting outdoor-fan motor and compressor. Circuit R-G energizes indoor-blower relay, starting blower motor on high speed.

Should temperature continue to fall, R-W2 is made through second-stage room-thermostat bulb. Circuit R-W2 energizes a sequencer, bringing on first bank of supplemental electric heat and providing electrical potential to second heater sequencer (if used). If outdoor temperature falls below setting of outdoor thermostat (field-installed option), contacts close to complete circuit and bring on second bank of supplemental electric heat.

When thermostat is satisfied, its contacts open, de-energizing contactor and sequencer. All heaters and motors should stop.

When the thermostat is satisfied, its contacts open, de-energizing contactor and sequencer. All heaters and motors should stop.

→ Quiet Shift

Quiet Shift is a field-selectable defrost mode, which will eliminate occasional noise that could be heard at the start of the defrost cycle and restarting of heating cycle. It is selected by placing DIP switch 3 (on defrost board) in ON position.

When Quiet Shift switch is placed in ON position, and a defrost is initiated, the following sequence of operation will occur. Reversing valve will energize, compressor will turn off for 30 sec, then turn back on to complete defrost. At the start of heating cycle after conclusion of defrost mode, reversing valve will de-energize, the compressor will turn off for another 30 sec, and the fan will turn off for 40 sec, before starting in the heating mode.

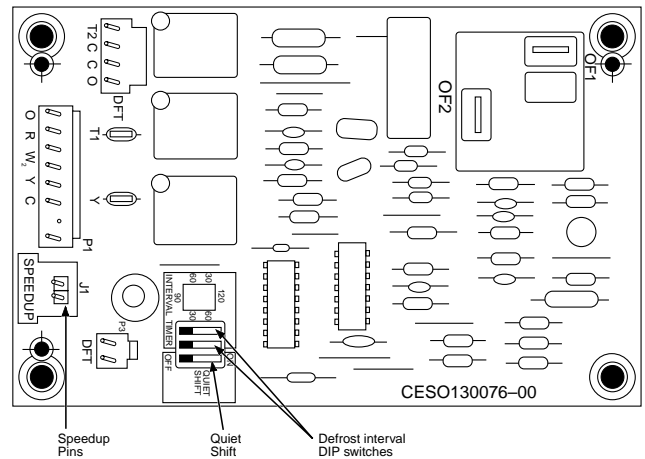

A91444

→

Fig. 8—Defrost Control

→ Defrost

The defrost control is a time/temperature control which includes a field-selectable time period (DIP switch 1 and 2 on the board) between defrost cycles of 30, 60, 90, or 120 minutes (factory set at 90 minutes).

To initiate a forced defrost, two options are available depending on the status of the defrost thermostat.

If defrost thermostat is closed, speedup pins (J1) must be shorted by placing a flat head screwdriver in between for 5 sec and releasing, to observe a complete defrost cycle. When the Quiet Shift switch is selected, compressor will be turned off for two 30 sec intervals during this complete defrost cycle as explained previously. When Quiet Shift switch is in factory default OFF position, a normal and complete defrost cycle will be observed.

If defrost thermostat is in open position, and speedup pins are shorted (with a flat head screwdriver) for 5 sec and released, a short defrost cycle will be observed (actual length is dependent upon the selected Quiet Shift position). When Quiet Shift switch is in ON position, the length of defrost is 1 minute (30 sec compressor off period followed by 30 sec of defrost with compressor operation). On return to heating operation, compressor will again turn off for an additional 30 sec and the fan for 40 sec. When the Quiet Shift is in OFF position, only a brief 30 sec cycle will be observed.

If it is desirable to observe a complete defrost in warmer weather, the thermostat must be closed as follows:

1. Turn off power to outdoor unit.
2. Disconnect outdoor fan motor lead from OF2 on control board. (See Fig. 8.) Tape to prevent grounding.
3. Restart unit in heating mode, allowing frost to accumulate on outdoor coil.
4. After a few minutes in heating mode, liquid line temperature should drop below closing point of defrost thermostat (approximately 30°F).

NOTE: Unit will remain in defrost until defrost thermostat reopens at approximately 80°F coil temperature at liquid line or remainder of defrost cycle time.

5. Turn off power to outdoor and reconnect fan motor lead to OF2 on control board after above forced defrost cycle.

Step 1—Final Checks

IMPORTANT: Before leaving job, be sure to do the following:

1. Securely fasten all panels and covers.
2. Tighten service valve stem caps to 1/12-turn past finger tight.
3. Leave User's Manual with owner. Explain system operation and periodic maintenance requirements outlined in manual.

CARE AND MAINTENANCE

For continuing high performance and to minimize possible equipment failure, periodic maintenance must be performed on this equipment.

Frequency of maintenance may vary depending upon geographic areas, such as coastal applications.